

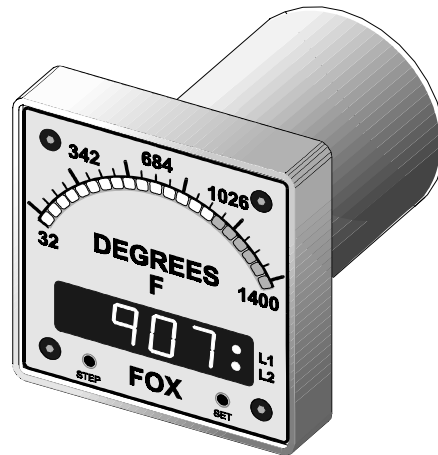

## FS11X - 500 TYPE J T/C INPUT METER INSTALLATION - SETUP - OPERATION

### FS11X-500 DESCRIPTION / SPECIFICATIONS

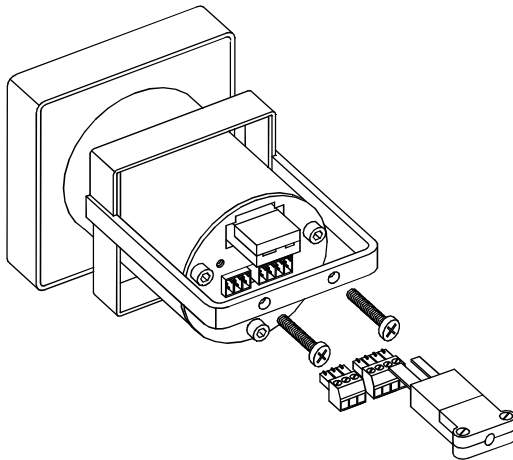

- DIGITAL DISPLAY - 4 Digit, 0.4" Tall Red LED; -1999 to 9999 display range
- BARGRAPH DISPLAY - 21 Element Red T1 LED's arranged in an arc above the digital display.
- ENCLOSURE - Painted steel, Aluminum and Stainless Steel
- FRONT OVERLAY - Laser engraved at time of order with user specified units label and bar scale
- MOUNTING - A separate stainless steel mounting bracket attaches to the rear of the meter and physically clamps the meter to the panel through a 2 1/8" round opening.
- OVERALL ACCURACY - Better than 0.5% +/-1 degree over operating temperature range.
- OPERATING TEMPERATURE RANGE - -25 Degrees C to +80 Degrees C
- STORAGE TEMPERATURE RANGE - -55 Degrees C to +80 Degrees C
- A/D CONVERTER RESOLUTION - 16 Bits ( 65536 counts )
- A/D CONVERSION RATE - 4000 Conversions / second
- DISPLAY UPDATE RATE - From 16 to 1 updates per second user selectable
- RESPONSE TIME - 0.5 seconds for full scale step
- OVER / UNDER RANGE INDICATION - Meter displays '-or-' or '-ur-' when input exceeds min/max displayable range or min/max input range
- BAR DISPLAY MODES - Left zero, moving dot and fill modes, menu selectable
- CALIBRATION / DISPLAY SCALING - Two menu steps allow calibration in mV (a known mV input is necessary for scaling). The meter automatically scales the mV input to display Fahrenheit or Celsius degrees.
- OPTIONAL SETPOINT RELAYS - 2 On-board 1 Amp @ 200 V AC/DC isolated MOSFET solid state relays with a 4 position socketed terminal block for connection are available. Each relay is independently programmable as NO (form A) or NC (form B).

**SIGNAL INPUT** - TYPE "J" THERMOCOUPLE. A miniature thermocouple connector is provided at the rear of the meter for signal connection.

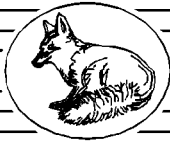

## FS11X-500 SERIES MOUNTING

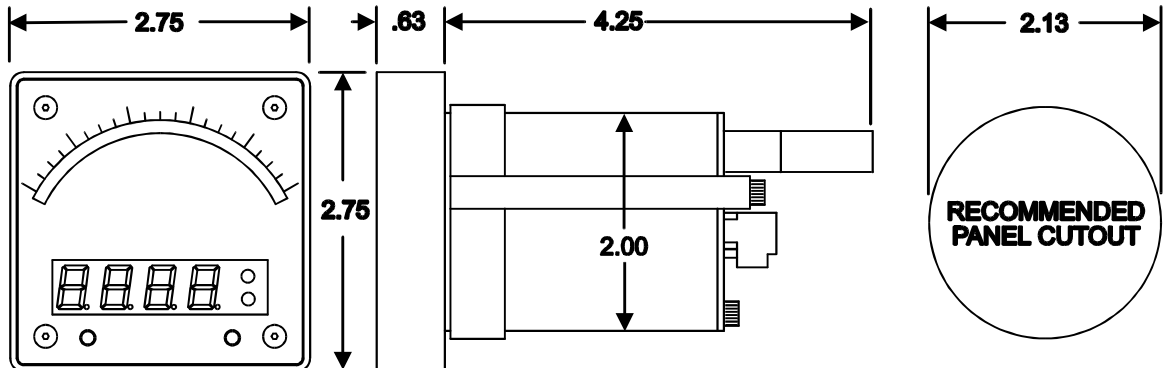

## FS11X-500 SERIES POWER SUPPLY SPECIFICATIONS

### FS111 - XXX 120 VAC UNITS

- INPUT VOLTAGE RANGE - 85 to 140 VAC
- INPUT FREQUENCY RANGE - 47 to 63 Hz
- POWER DISSIPATION - Less than 3 VA typical

- P2 WIRING**
- P2 - 1 : Neutral Line
  - P2 - 2 : 120 VAC Hot Line
  - P2 - 3 : Chassis ground

### FS113 - XXX 240 VAC UNITS

- INPUT VOLTAGE RANGE - 190 to 260 VAC
- INPUT FREQUENCY RANGE - 47 to 63 Hz
- POWER DISSIPATION - Less than 3 VA typical

- P2 WIRING**
- P2 - 1 : 240 VAC Hot Line
  - P2 - 2 : 240 VAC Hot Line
  - P2 - 3 : Chassis ground

### FS115 - XXX 5 TO 12 VDC UNITS

- INPUT VOLTAGE RANGE - 5 TO 12 VDC
- PERMISSABLE RIPPLE - 200 mV Max
- INPUT CURRENT - Less than 200 mA typical

- P2 WIRING**
- P2 - 1 : +DC
  - P2 - 2 : Power supply ground
  - P2 - 3 : Chassis ground

### FS116 - XXX 5 TO 12 VDC ISOLATED UNITS

- INPUT VOLTAGE RANGE - 5 TO 12 VDC
- PERMISSABLE RIPPLE - 200 mV Max
- INPUT CURRENT - Less than 200 mA typical
- POWER SUPPLY ISOLATION - 750 Volts isolation between power supply and signal input

- P2 WIRING**
- P2 - 1 : +DC
  - P2 - 2 : Power supply ground
  - P2 - 3 : Chassis ground

### FS117 - XXX 10 TO 30 VDC UNITS

- INPUT VOLTAGE RANGE - 10 TO 30 VDC
- PERMISSABLE RIPPLE - 500 mV Max
- INPUT CURRENT - Less than 150 mA typical

- P2 WIRING**
- P2 - 1 : +DC
  - P2 - 2 : Power supply ground
  - P2 - 3 : Chassis ground

### FS118 - XXX 10 TO 30 VDC ISOLATED UNITS

- INPUT VOLTAGE RANGE - 10 TO 30 VDC
- PERMISSABLE RIPPLE - 500 mV Max
- INPUT CURRENT - Less than 150 mA typical
- POWER SUPPLY ISOLATION - 750 Volts isolation between power supply and signal input

- P2 WIRING**
- P2 - 1 : +DC
  - P2 - 2 : Power supply ground
  - P2 - 3 : Chassis ground



## FS11X - 500 SERIES WIRING GUIDE

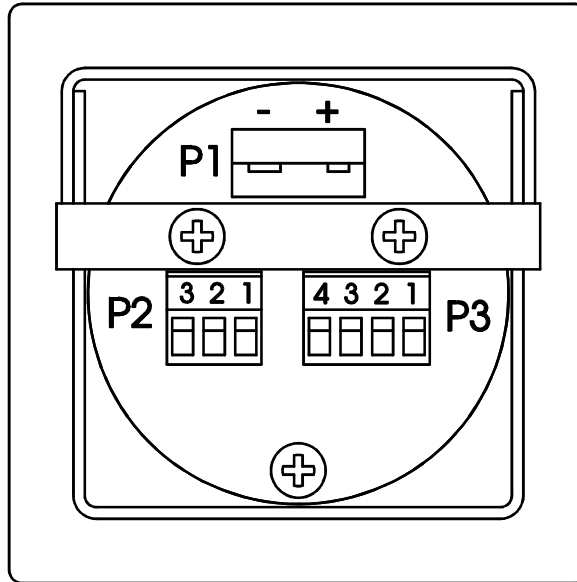

REAR VIEW OF FS11X-XXX SERIES UNITS

### P1 - SIGNAL INPUT

THERMOCOUPLE INPUT, POLARITY AS INDICATED

### P2 - POWER INPUT

SEE POWER SUPPLY SPECIFICATIONS FOR CONNECTION INFORMATION. NOTE: THE THERMOCOUPLE INPUT PIN IS REFERENCED TO THE POWER SUPPLY GROUND ON FS11X SERIES METERS. WHEN USING DC POWERED FS11X SERIES METERS, CARE MUST BE TAKEN TO AVOID CREATION OF GROUND LOOPS WITH SIGNAL WIRING. IF GROUND LOOPS ARE A CONSIDERATION, USE AC POWER OR ISOLATED DC POWERED UNITS.

### P3 - SETPOINT OUTPUTS

P3-1 & P3-2 = SETPOINT 1

P3-3 & P3-4 = SETPOINT 2

## FS11X - XXX SERIES FRONT PANEL CONTROLS

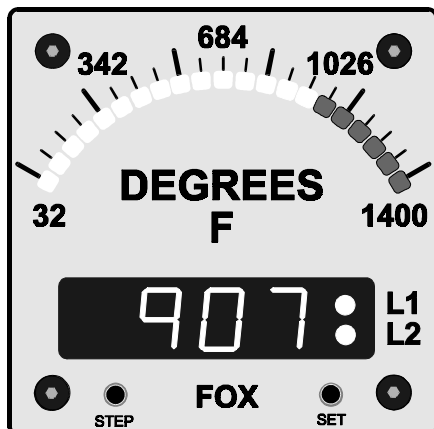

### STEP

- PRESS TO ENTER THE SETUP MENU
- WHILE IN THE MENU MODE, PRESS THIS BUTTON TO ADVANCE TO THE NEXT PARAMETER OR TO THE NEXT DIGIT

### SET

- WHILE IN THE MENU MODE, THIS BUTTON CHANGES THE SETTING FOR A PARAMETER OR INCREMENTS THE FLASHING DIGIT



## FS11X - 500 SERIES SET-UP MENU

PARAMETER	SETTING	DESCRIPTION
TEMPERATURE SCALE	t.S. F	DISPLAY IN DEGREES FARENHEIT (32 - 2,192 DEGREES F)
	t.S. C	DISPLAY IN DEGREES CELSIUS (0 - 1,200 DEGREES C)
	t.S. V	DISPLAY IN mV
AVERAGING: NUMBER OF SETS OF 256 CONVERSIONS AVERAGED TOGETHER FOR DISPLAY UPDATE	Av.16	4096 CONVERSIONS AVERAGED; 1 UPDATE / SECOND
	Av. 8	2048 CONVERSIONS AVERAGED; 2 UPDATES / SECOND
	Av. 4	1024 CONVERSIONS AVERAGED; 4 UPDATES / SECOND
	Av. 2	512 CONVERSIONS AVERAGED; 8 UPDATES / SECOND
	Av. 1	256 CONVERSIONS AVERAGED; 16 UPDATES / SECOND
BAR MODE	FILL	BAR DISPLAY FILLS FROM LEFT
	dot	MOVING DOT BAR DISPLAY
BAR STARTING POINT	[1][2][3][4]	ENTER DISPLAY VALUE AT LEFT END OF BAR
BAR ENDING POINT	[1][2][3][4]	ENTER DISPLAY VALUE AT RIGHT END OF BAR
SETPOINT 1 LEVEL	S1.no	SETPOINT 1 OPEN WHEN DISPLAY IS BELOW SP1 VALUE
	S1.nc	SETPOINT 1 CLOSED WHEN DISPLAY IS BELOW SP1 VALUE
SETPOINT 1 VALUE	[1][2][3][4]	ENTER SETPOINT 1 DISPLAY VALUE
SETPOINT 2 LEVEL	S2.no	SETPOINT 2 OPEN WHEN DISPLAY IS BELOW SP2 VALUE
	S2.nc	SETPOINT 2 CLOSED WHEN DISPLAY IS BELOW SP2 VALUE
SETPOINT 2 VALUE	[1][2][3][4]	ENTER SETPOINT 2 DISPLAY VALUE
CAL POINT 1	CAL1	ANNOUNCES CAL 1 STEP *
	[1][2][3][4]	ADJUST DISPLAY TO DESIRED mV VALUE FOR CAL 1 INPUT *
CAL POINT 2	CAL2	ANNOUNCES CAL 2 STEP *
	[1][2][3][4]	ADJUST DISPLAY TO DESIRED mV VALUE FOR CAL 2 INPUT *

### TO SET A CALIBRATION / SCALING VALUE:

- PRESS AND RELEASE THE 'SET' BUTTON UNTIL THE FLASHING DIGIT REACHES THE DESIRED VALUE
- PRESS THE 'STEP' BUTTON TO ADVANCE TO THE NEXT DIGIT
- REPEAT UNTIL ALL DIGITS ARE SET
- NOTE: LEADING ZERO SUPPRESSION IS DISABLED DURING SETUP MENU OPERATION, ALL FOUR DIGITS MUST DISPLAY A NUMBER

### \*CALIBRATION / SCALING INSTRUCTIONS:

- THE FS11X - 500 SERIES METER REQUIRES A TYPE 'J' THERMOCOUPLE SIMULATOR FOR CALIBRATION.
- APPLY 0.00mV (0 DEGREES C, 32 DEGREES F) TO THE METER INPUT.
- USING THE 'STEP' BUTTON, SCROLL THROUGH THE SETUP MENU UNTIL THE SETPOINT 2 LEVEL STEP APPEARS. USE THE STEP BUTTON TO ADVANCE TO THE LAST (ONES) DIGIT. PRESS AND HOLD THE 'STEP' BUTTON. WHILE HOLDING THE STEP BUTTON, PRESS AND RELEASE THE SET BUTTON. THE CAL1 MESSAGE WILL BE REPLACED BY A NUMBER WITH THE MSD (LEFT) DIGIT FLASHING.
- ADJUST THE VALUE ON THE DISPLAY UNTIL IT AGREES WITH THE mV VALUE OF THE KNOWN INPUT - SEE ABOVE INSTRUCTIONS TO SET A CALIBRATION / SCALING VALUE..
- PRESS THE 'STEP' BUTTON, THE 'ENT 1' MESSAGE WILL APPEAR MOMENTARILY AND THEN BE REPLACED WITH THE CAL2 MESSAGE- PRESS 'STEP' ONCE MORE- A NUMBER WILL APPEAR WITH THE MSD (LEFT) DIGIT FLASHING.
- APPLY 40.00mV (714 DEGREES C, 1317 DEGREES F) TO THE METER INPUT.
- ADJUST THE VALUE ON THE DISPLAY UNTIL IT AGREES WITH THE mV VALUE OF THE KNOWN INPUT - SEE ABOVE INSTRUCTIONS TO SET A CALIBRATION / SCALING VALUE.
- PRESS 'STEP' BUTTON TO ENTER THE CAL POINT, CALIBRATION / SCALING IS COMPLETE - THE METER WILL RETURN TO NORMAL OPERATION.
- NOTE: VALUES INDICATED FOR CAL1 AND CAL2 INPUTS ARE SUGGESTED. OTHER VALUES MAY BE USED AS LONG AS THE mV OUTPUT IS KNOWN.



# FOX

## WARRANTY

- FOX METER INC., warrants its products to be free from defective material or workmanship for a period of two years from date of purchase.
- FOX METER INC., under this warranty is limited to repairing the defective device when returned to the factory, shipping charges prepaid, within two full years from date of purchase.
- This warranty is transferrable to second and third parties and will remain in force for the two year term from date of original purchase from FOX METER INC.
- Units returned to FOX METER INC., that have been subject to abuse, misuse, damage or accident, or have been connected, installed or adjusted contrary to the instructions furnished by FOX METER INC., or that have been repaired by unauthorized persons will not be covered by this warranty.
- The purchaser agrees to assume all liabilities for any damages and/or bodily injury which may result from the use or misuse of the device by the purchaser, his employees, or agents.
- This warranty is in lieu of all other representations or warranties, expressed or implied and no agent or representative of FOX METER INC., is authorized to assume any other obligation in connection with the sale and purchase of FOX METER INC., products.
- The terms of this warranty will only be honored if the products or equipment for which warranty service has been requested have been paid for in full by the original purchaser within the agreed upon terms and conditions of sale.

### \* NOTE \*

- While FOX METER INC., provides application assistance on its products, personally and through our literature, it is the responsibility of the customer to determine the compatibility of the product in the application.

## FACTORY SERVICE AND REPAIR

- FOX METER INC., will service and repair this instrument free of charge for the period of two years, subject to the warranty conditions above.
- When returning any defective product to FOX METER INC., please include any information that may pertain to the problem and please include the name of the individual for us to contact, along with your company name, address and phone number.

## RETURN REPAIRS TO

**FOX METER INC.  
5403 Patton Dr. Unit 218  
Lisle, IL 60532  
ATTN: Service Department**